

1200 WESTINGHOUSE | SUITE G

CHARLOTTE, NC 28273

COMMERCE PARK | SOUTHWEST SUBMARKET



±15,790 SF AVAILABLE FOR LEASE

- ±1,630 SF of office space
- Frontage on Westinghouse Boulevard
- Front load facility
- ML-2 zoning
- Wet sprinkler
- 20' ceiling height
- Dock loading:
(3) 8' x 10' dock high doors; Two (2) w/edge leveler
- Brick on block construction
- Master planned, institutional quality park
- Ideal Central Charlotte location:
±1 mile to I-77
±2 miles to I-485
±6.5 miles to Charlotte Douglas International Airport



ALEX HABECKER

704.926.1412 (d) 407.473.0051 (m)

alex@beacondevelopment.com

1200 WESTINGHOUSE | SUITE G

CHARLOTTE, NC 28273

COMMERCE PARK | SOUTHWEST SUBMARKET

AERIAL & FLOOR PLAN

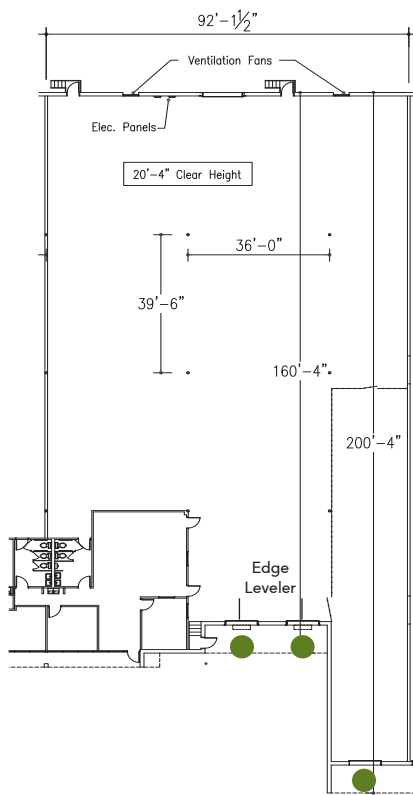
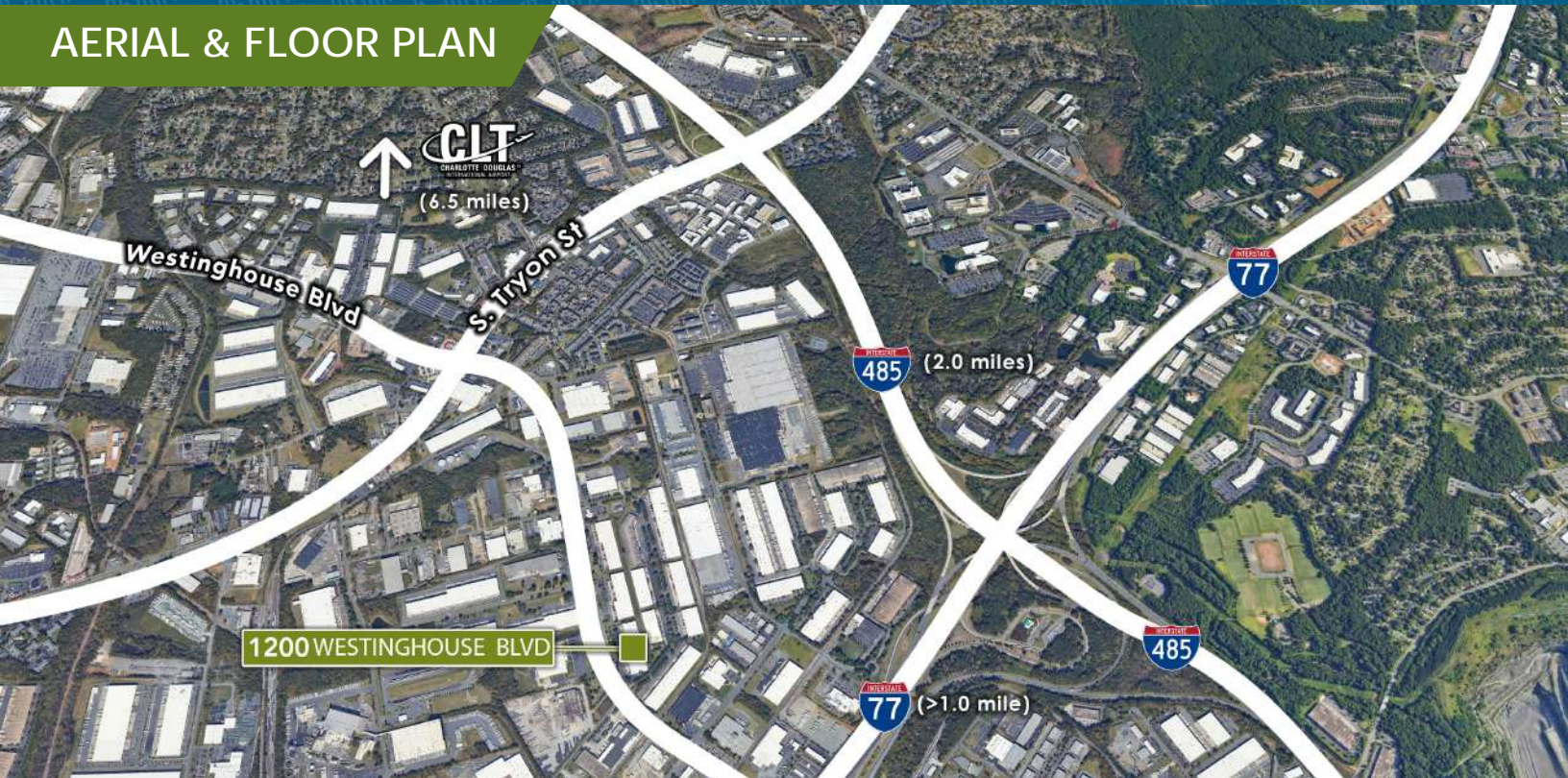

● Dock-high door



1200 WESTINGHOUSE BLVD.
SUITE G
15,790 SF
1,630 OFFICE SF

2 Dock High Doors (8x10)
2 Dock High Doors w Edge Levelers (8x10)
1 Rail Door (10x10)



BEACON
PARTNERS

ALEX HABECKER

704.926.1412 (d) 407.473.0051 (m)

alex@beacondevelopment.com