

2905 WESTINGHOUSE BLVD | SUITE 700

CHARLOTTE, NC 28273

MAPLECREST INDUSTRIAL CENTER | SOUTH WEST SUBMARKET



2,400 SF AVAILABLE FOR LEASE

- 2,400 SF available with 520 SF of office
- One dock-high door (9' x 10')
- One drive-in door (10' x 14')
- 18' clear height
- ML-2 zoning
- Wet sprinkler
- Ample parking and gated truck court
- Ideal Central Charlotte location:
 - ±4 minutes to I-485
 - ±5 minutes to I-77
 - ±15 minutes to Charlotte Int'l Airport
 - ±15 minutes to Charlotte CBD

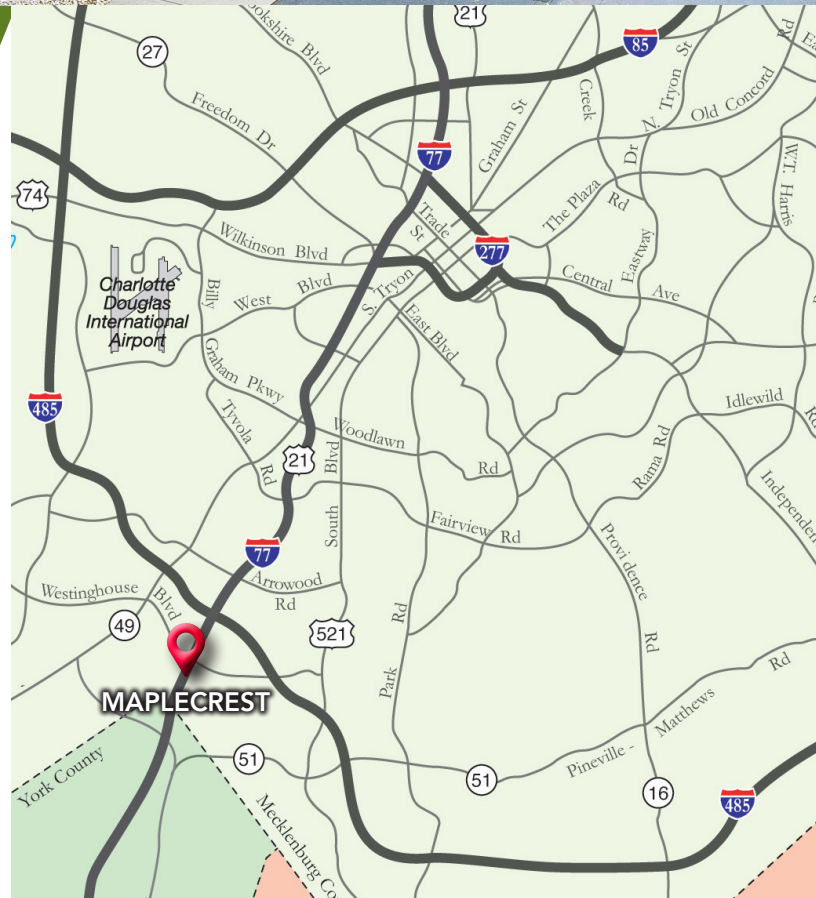

ALEX HABECKER

704.926.1412 (d) 407.473.0051 (m)

alex@beacondevelopment.com

2905 WESTINGHOUSE BLVD | SUITE 700

CHARLOTTE, NC 28273

MAPLECREST INDUSTRIAL CENTER | SOUTH WEST SUBMARKET

AERIAL & SITE PLAN

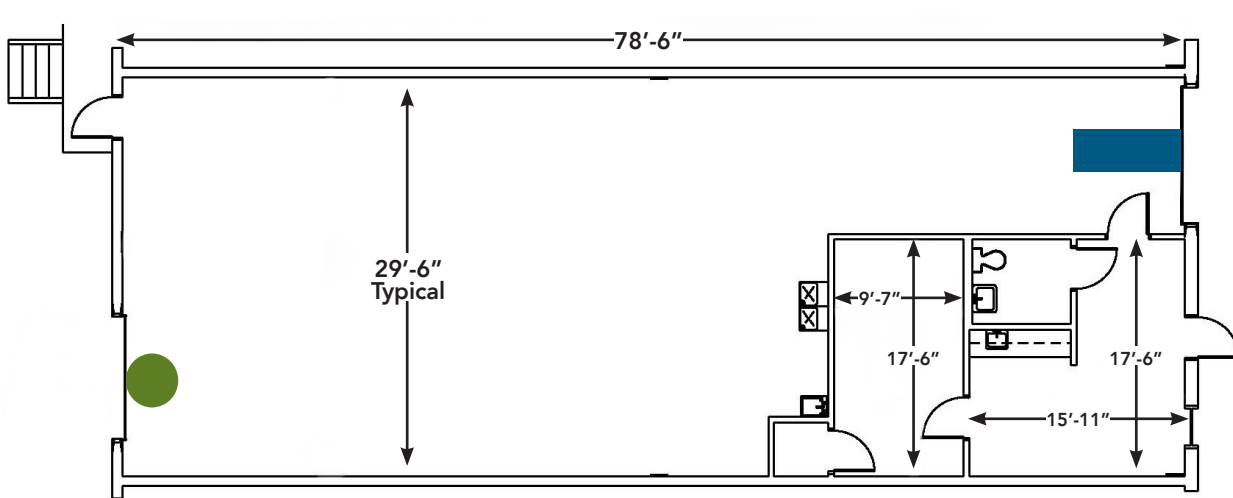
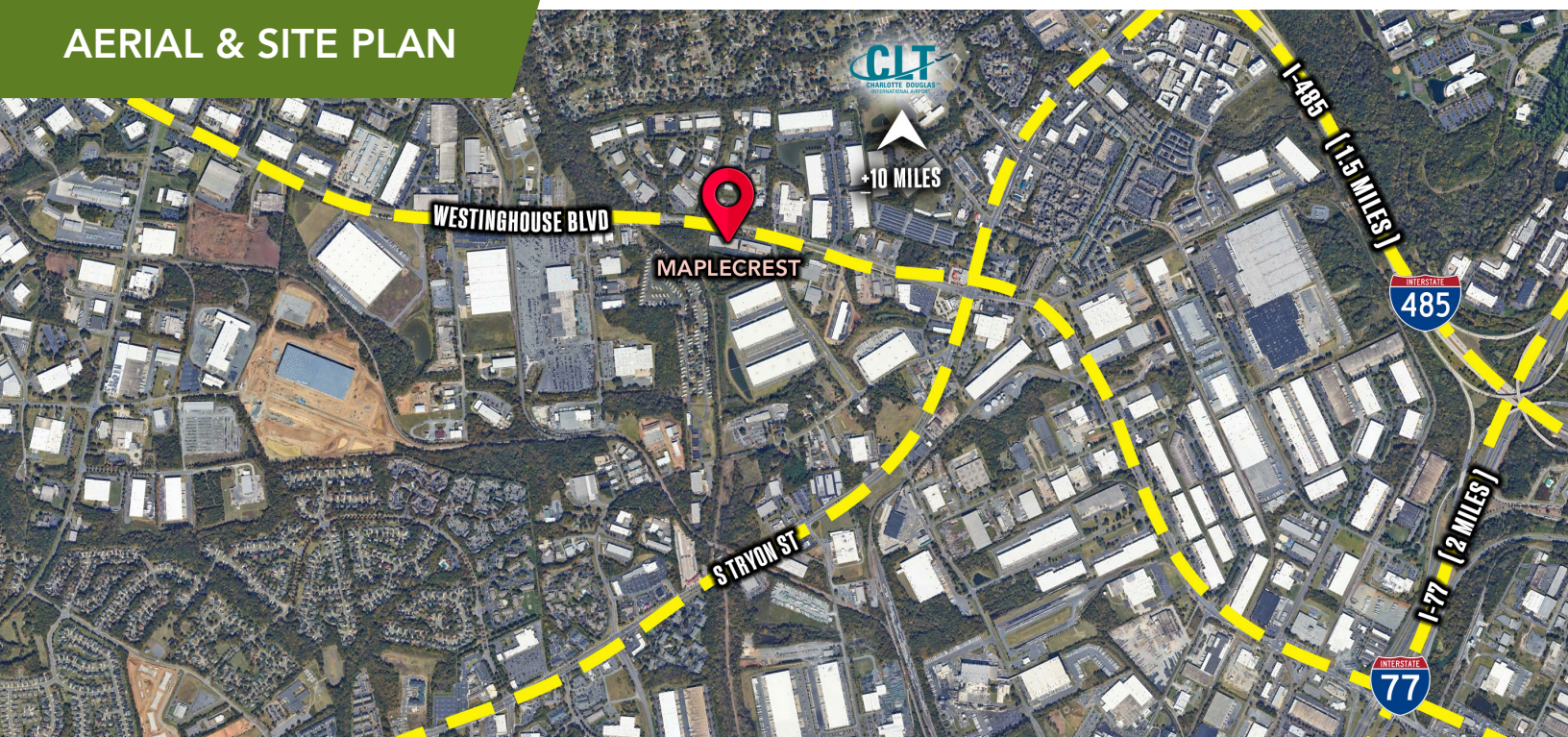

● = Dock-high door ■ = Drive-in door

