

±34,127 SF WAREHOUSE FOR LEASE | CSX RAIL SPUR

NORTHWEST INDUSTRIAL PARK | 839 EXCHANGE ST, SUITE J | CHARLOTTE, NC 28208



FEATURES:

- ±34,127 SF warehouse / distribution facility with ±893 SF of office space
- CSX rail spur
- Two (8' x 10') dock high doors with edge of dock levelers
- One (20' x 14') drive-in door
- One (20' x 14') rail door / One (16' x 12') rail door
- 22' clear height / 40' x 41'8" column spacing
- 105' fenced truck court
- Fully sprinklered
- Convenient to:
 - I-85 (±2 miles)
 - I-485 (±5 miles)
 - Charlotte Douglas International Airport (±5 miles)



FOR MORE INFORMATION, CONTACT:

PETE KIDWELL

704.926.1404 (d) 704.654.9343 (m)

kidwell@beacondevelopment.com

500 East Morehead Street | Suite 200 | Charlotte, NC 28202

www.beacondevelopment.com



±34,127 SF WAREHOUSE FOR LEASE | CSX RAIL SPUR

NORTHWEST INDUSTRIAL PARK | 839 EXCHANGE ST, SUITE J | CHARLOTTE, NC 28208

FLOOR PLAN

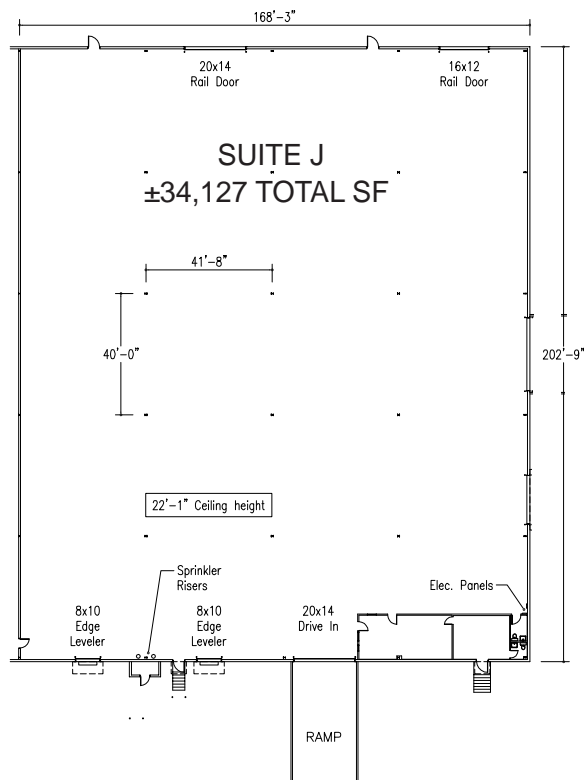
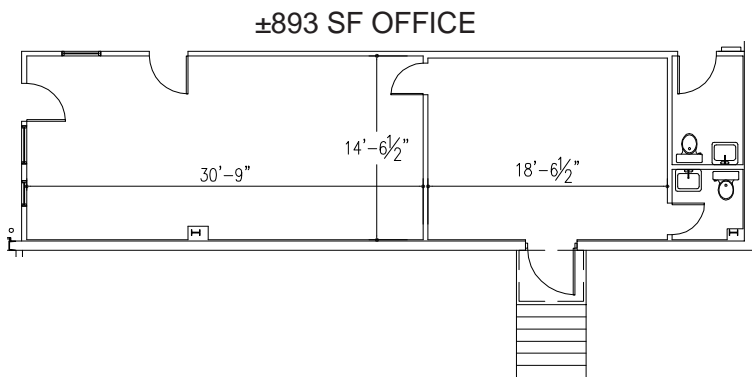

AERIALS



All information regarding the property was obtained from sources deemed reliable but no warranty or representation is made of the accuracy thereof and the property is subject to prior sale, lease or withdrawal.

FOR MORE INFORMATION, CONTACT:

PETE KIDWELL

704.926.1404 (d) 704.654.9343 (m)

kidwell@beacondevelopment.com

500 East Morehead Street | Suite 200 | Charlotte, NC 28202

www.beacondevelopment.com

